

TABLE II  
PV/M RELATIONS AT 0°

Gas	PV/M cc.-atm./mole	Valid range, atm.	Deviation coef., $\lambda$
CH <sub>3</sub> NH <sub>2</sub>	22,404-942 atm.	0-1.000	-0.0420
(CH <sub>3</sub> ) <sub>2</sub> NH	22,413-1,254	0-0.737	-0.0560
(CH <sub>3</sub> ) <sub>3</sub> N	22,393-1,188	0-0.895	-0.0531

The valid range was determined by the value of the vapor pressure of the liquid amine at 0°; thus the vapor pressures are 1.349, 0.737<sup>7</sup> and 0.895 atmospheres for the mono-, di- and trimethylamines, respectively.

The deviation coefficient was evaluated by

(7) Swift and Hochanadel, *Proc. Indiana Acad. Sci.*, **54**, 121 (1945).

means of the relation proposed by Dietrichson, Orleman and Rubin<sup>5</sup> at constant temperature

$$\lambda = \frac{1}{(\overline{PV})_{P \rightarrow 0}} \times \frac{\partial(PV)}{\partial P}$$

### Summary

The densities of the gaseous methylamines have been determined at 0° and at pressures ranging from 0.2 to approximately 0.8 atm.

The equations of state at 0°, the limiting molar volumes and the deviation coefficients have been evaluated.

AUSTIN, TEXAS

RECEIVED JUNE 24, 1946

[CONTRIBUTION FROM THE CHEMICAL LABORATORY OF THE JOHNS HOPKINS UNIVERSITY]

## The Nature of the N-H Bond in the Porphyrins<sup>1</sup>

BY J GORDON ERDMAN<sup>2</sup> AND ALSOPH H. CORWIN

Since the discovery of the phenomenon of "hydrogen bridging" there has been discussion as to whether or not the bond is symmetrical with the hydrogen midway between the other two atoms involved. In general, it has been concluded that these bonds are unsymmetrical.<sup>3</sup> A peculiarly favorable case for symmetrical bonding exists in the porphyrins, for although a pair of adjacent nitrogens and a hydrogen cannot form a straight line, the nitrogens are close enough to permit symmetrical placement of the hydrogens and are constrained in their positions by large forces which are independent of the hydrogen bonds. The present paper is an attempt to find by gross examination of spectra whether or not the bonding is symmetrical.

An alternative to hydrogen bonding has been proposed in the case of the porphyrins. Corwin and Quattlebaum<sup>4</sup> suggested that N isomerism might possibly exist with hydrogens attached in some cases to adjacent nitrogens. They pointed out that the formation of acid salts or metallo complexes would result in "resonance" isomers and consequent interconversion of the two forms. They believed that in view of the short N-H-N distance, hydrogen bridging might play a part in porphyrin structure and suggested the synthesis and study of N-methyl porphyrins to settle the question.

Opinion is still divided between the hypothesis of N isomers and that of hydrogen bridging.

(1) Studies in the Pyrrole Series XVII; Paper XVI, Ellingson and Corwin, *THIS JOURNAL*, **68**, 1112 (1946). This paper was presented at the New York Meeting of the American Chemical Society, September, 1944.

(2) Present address: Mellon Institute, University of Pittsburgh, Pittsburgh, Pennsylvania.

(3) See Wheland, "The Theory of Resonance," John Wiley and Sons, Inc., New York, N. Y., 1944, pp. 44-51.

(4) Corwin and Quattlebaum, *THIS JOURNAL*, **58**, 1081 (1936).

Robertson,<sup>5</sup> Vestling and Downing<sup>6</sup> and Aronoff and Weast<sup>7</sup> after physical studies favor the hypothesis of hydrogen bridging. On the other hand Rothemund<sup>8</sup> and Rothemund and Menotti<sup>9</sup> in their syntheses of porphyrin and the  $\alpha, \beta, \gamma, \delta$ -substituted porphyrins from pyrrole and aldehyde obtained pairs of presumably isomeric porphyrins which could be separated by acid fractionation. These authors and their collaborators<sup>10</sup> assume these to be N isomers. It should be pointed out that separation by acid fractionation implies that the nitrogens do not become equivalent even in the diacid salt. Stable "resonance" isomers of this type are without analogy in the literature.<sup>11</sup> The fact that N-methyl porphyrins are now available<sup>12</sup> makes it possible to learn more about the nature of the N-H bonding in the ring. The studies reported herewith lead us to conclude that it is unlikely that symmetrical N-H-N bonds exist in the porphyrin ring. A hydrogen atom in a porphyrin ring is probably bonded to a single nitrogen atom at any instant even though it may be within the field of force of the adjacent nitrogen atom at the time.

The Küster formula for porphyrin represents a highly conjugated system, the bond arrangement of which is arbitrary just as in the Kekulé formula for benzene. It is natural to seek to achieve a better representation of the porphyrin structure through superimposition of "Kekulé" and hybrid

(5) Robertson, *J. Chem. Soc.*, 1195 (1936).

(6) Vestling and Downing, *THIS JOURNAL*, **61**, 3511 (1939).

(7) Aronoff and Weast, *J. Org. Chem.*, **6**, 550 (1941).

(8) Rothemund, *THIS JOURNAL*, **57**, 2010 (1935); **58**, 635 (1936); **61**, 2912 (1939).

(9) Rothemund and Menotti, *ibid.*, **63**, 267 (1941).

(10) Albers and Knorr, *J. Chem. Phys.*, **4**, 422 (1936); Knorr and Albers, *ibid.*, **9**, 197 (1941).

(11) See Aronoff and Calvin, *J. Org. Chem.*, **8**, 205 (1943).

(12) McEwen, *THIS JOURNAL*, **68**, 711 (1946).

ion forms, as in the benzene series. The analogy with the latter is borne out experimentally by the low energies (long wave lengths) of the electronic absorption limits.

If the hydrogens are uniquely fixed on specific nitrogens, two Kekulé forms are possible

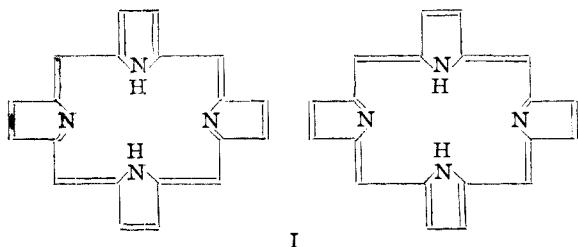

I

Above these in energy are hybrid ion forms of the type  $N^+N^-$ ,

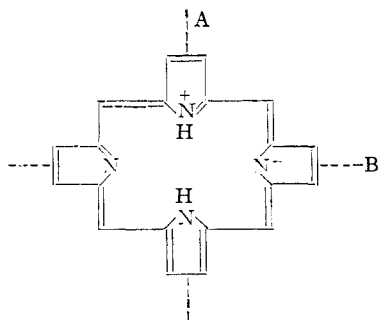

II

whose contribution would render the hydrogens acidic. Still other forms charged on carbon may also be written.

In the case of equally shared hydrogens, the four nitrogens are identical and twelve forms of like energy can be written for the system.

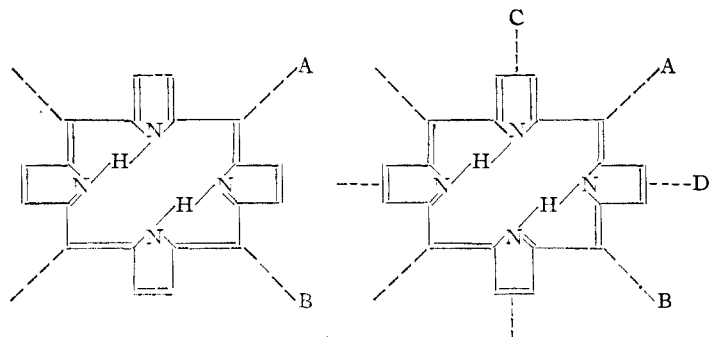

Twelve forms obtained by alternate reflections across the four axes A, B, C and D.

III

The possible bond arrangements in the case of shared hydrogens are essentially the same as in the porphyrin diacid, the dibase, and the complexes of the divalent transition metals, such as copper.

The spectral absorption curves of the diacid and dibase (Fig. 1, Curves A and B) are very similar, the bands falling at 597.5, 555.0 and

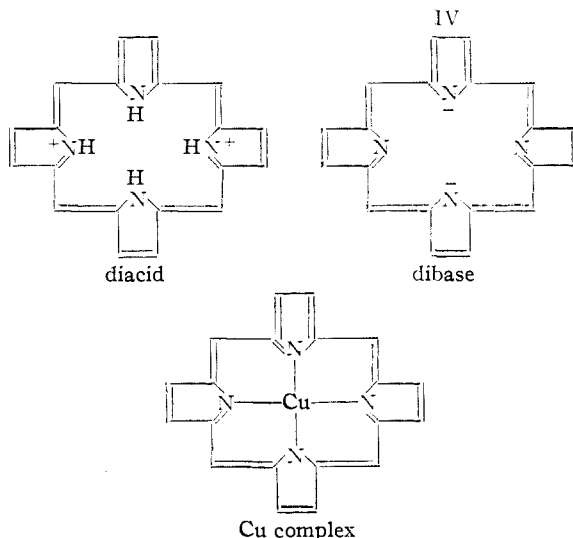

414.0  $m\mu$  (great peak) for the former, and 590.0, 552.5 and 417.0  $m\mu$  (great peak) for the latter. The shift in charge and the presence or absence of hydrogens are thus of slight importance in relation to bond distribution. The copper complex (Fig. 2) possesses the same general form, 565.0, 525.0 and 395.0  $m\mu$  (great peak), the only change being the shift of the absorption maxima to the violet.

The spectrum of the porphyrin free base (Fig. 3 Curve A) is drastically different. The former pair of bands, to the red of the great peak, is now replaced by a set of four at 620.0, 570.0, 530.0 and 497.5  $m\mu$ . This indicates a very different bond distribution, such as would result by the destruction of the equivalence of the nitrogens through unique placement.

The synthesis of N-methyletioporphyrin II makes possible a check on the reasoning above. With one nitrogen tagged by a methyl group, the possibility of nitrogen equivalence is destroyed. On the basis of the hypothesis of hydrogen sharing a drastic change in the spectrum would be expected. If, however, the hydrogens are uniquely placed for periods of time longer than that required for the absorption of a photon and the life of the electronically excited form, the number of stable electronic forms remains constant. On the basis of this hypothesis substitution of a methyl group for a hydrogen should introduce only a slight perturbation such as a shift to the red similar to that obtained through substitution on the outer edge of the ring.

The spectrum of the N-methylporphyrin (Fig. 3, Curve B) shows a shift to the red, the bands falling at 641.0, 587.0, 530.0, 502.0 and 405.0  $m\mu$  (great peak). The essential four banded spectrum of the free base is retained, the shift

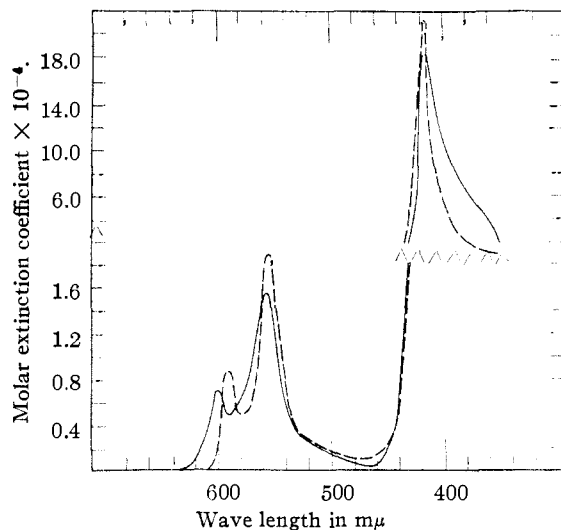

Fig. 1.—Spectrophotometric curves: (A) ———, etioporphyrin II dihydrochloride; (B) ---, etioporphyrin II disodium salt.

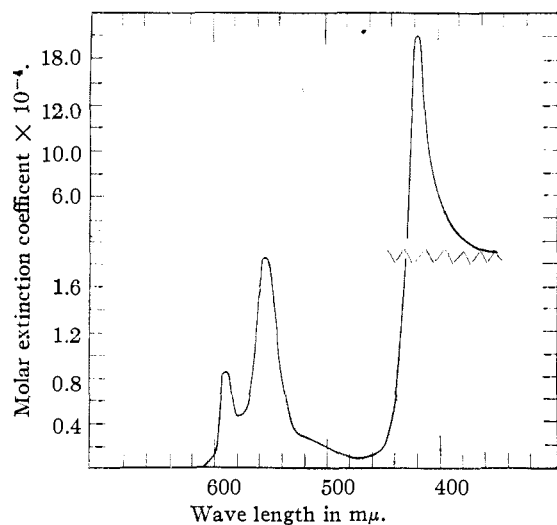

Fig. 2.—Absorption curve of the copper complex of etioporphyrin II.

being similar to that obtained when a group such as carboxyl or vinyl is placed on the ring.

These considerations lead to the conclusion that, though some hydrogen bridging may be present, complete sharing with the hydrogens in the center between adjacent nitrogens does not take place. This does not mean that stable opposite and adjacent isomers necessarily exist but simply that the hydrogens remain fixed to specific individual nitrogens for periods of time exceeding the period of existence of an excited form, that is, about  $10^{-12}$  seconds. On the other hand, the proximity of the adjacent nitrogens and the possible contribution of the charged forms (Fig. 2) as well as the experimentally demonstrated acidity of these hydrogens, indicate a very low energy hump for the shift of a hydrogen from one nitrogen

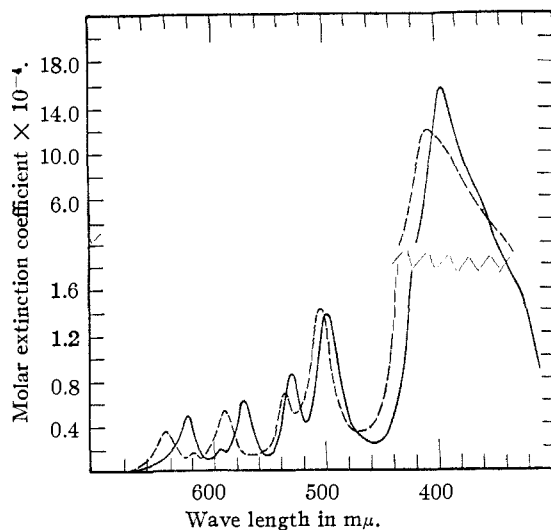

Fig. 3.—Absorption curves: (A) ———, etioporphyrin II, free base; (B) ---, N-methyletioporphyrin II, free base.

to another. All these factors lead us to conclude that interconversion of the N isomers should be rapid.

One of the authors (J. G. E.) wishes to acknowledge a grant-in-aid from the Hynson, Westcott and Dunning Research Fund.

### Experimental

**The Instruments.**—The region 1000 to 350  $m\mu$  was covered with a Coleman Model 10-S Double Monochromator Spectrophotometer equipped with a 5  $m\mu$  slit. The photocell potential was measured by a Coleman Model 310 Potentiometer set to operate on sixty millivolts. Square cuvettes 1.301-cm. thick, matched by the maker to  $\pm 0.25\%$  over the entire spectral region, were used in all cases.

Alignment of the slit and grating was necessary for maximum resolution. Calculations showed that a deviation of forty-nine minutes of rotation relative to each other effectively doubles the slit width. Direct visual settings were not sufficiently accurate even when set against the bands of didymium glass. A scale was engraved on one edge of the slit holder and a base line on the socket. The slit holder was rotated a unit at a time until maximum resolution was obtained.

The wave length scale was calibrated against Coleman PC-7 Filter (Corning 512 Didymium glass).

The per cent. transmission could be reproduced to approximately 1%. The error in the molar extinction coefficient is a function of the transmission reading, increasing toward both ends of the curve. To get maximum precision, it was necessary to use at least two dilutions in covering the curve. A determination of the degree of obedience to Beer's law is given for each curve.

The region 350 to 210  $m\mu$  was covered on a

TABLE I  
ETIOPORPHYRIN II IN DIOXANE  
Maxima

$\lambda$	I $\epsilon \times 10^{-4}$	Ia $\epsilon \times 10^{-4}$	$\lambda$	II $\epsilon \times 10^{-4}$	$\lambda$	III $\epsilon \times 10^{-4}$	$\lambda$	IV $\epsilon \times 10^{-4}$	$\lambda$	V $\epsilon \times 10^{-4}$	
622	0.480	595	0.195	572	0.621	532	0.850	498	1.37	397	15.7

## Minima

$\lambda$	I $\epsilon \times 10^{-4}$	$\lambda$	II $\epsilon \times 10^{-4}$	$\lambda$	III $\epsilon \times 10^{-4}$	$\lambda$	IV $\epsilon \times 10^{-4}$	$\lambda$	V $\epsilon \times 10^{-4}$
605	0.100	590	0.162	552	0.140	518	0.434	455	0.240

Beer's law (Estimated error in the measurement is given in parentheses)

Concentrations	$5.35 \times 10^{-6} M$	$1.07 \times 10^{-6} M$
$\epsilon \times 10^{-4}$ for peak I	0.483 (3%)	0.460 (7%)
II	.621 (2.7%)	.600 (6%)
III	.530 (2.7%)	.540 (6.5%)
IV	1.28 (6%)	1.38 (3%)

## N-METHYLETIOPORPHYRIN II IN DIOXANE

## Maxima

$\lambda$	I $\epsilon \times 10^{-4}$	Ia $\epsilon \times 10^{-4}$	$\lambda$	II $\epsilon \times 10^{-4}$	$\lambda$	III $\epsilon \times 10^{-4}$	$\lambda$	IV $\epsilon \times 10^{-4}$	$\lambda$	V $\epsilon \times 10^{-4}$	
641	0.327	615	0.161	587	0.454	525	0.504	502	1.41	405	11.8

## Minima

$\lambda$	I $\epsilon \times 10^{-4}$	$\lambda$	II $\epsilon \times 10^{-4}$	$\lambda$	III $\epsilon \times 10^{-4}$	$\lambda$	IV $\epsilon \times 10^{-4}$	$\lambda$	V $\epsilon \times 10^{-4}$
625	0.140	610	0.122	560	0.115	525	0.504	465	0.335

## Beer's law

Concentrations	$6.31 \times 10^{-6} M$	$1.05 \times 10^{-6} M$
$\epsilon \times 10^{-4}$ for peak I	0.327 (3%)	0.337 (8%)
II	0.454 (2.7%)	0.475 (7%)
III	0.625 (2.9%)	0.653 (5.6%)
IV	1.39 (5%)	1.41 (3.5%)

ETIOPORPHYRIN II DIHYDROCHLORIDE.—The etioporphyrin free base was dissolved in dioxane and diluted with dioxane containing dry hydrogen chloride. The final concentration of hydrogen chloride was 1%.

## Maxima

$\lambda$	I $\epsilon \times 10^{-4}$	$\lambda$	II $\epsilon \times 10^{-4}$	$\lambda$	III $\epsilon \times 10^{-4}$
598	0.680	555	1.54	415	18.1

## Minima

$\lambda$	I $\epsilon \times 10^{-4}$	$\lambda$	II $\epsilon \times 10^{-4}$
487	0.480	460	0.0216

## Beer's law

Concentrations	$5.35 \times 10^{-6} M$	$4.46 \times 10^{-6} M$
$\epsilon \times 10^{-4}$ for peak I	1.54 (4%)	1.53 (6%)
II	0.680 (2.5%)	0.674 (8%)

ETIOPORPHYRIN II DISODIUM SALT.—The etioporphyrin free base was dissolved in dioxane and treated with a methanol solution of sodium methoxide. The final proportions were dioxane 80%, methanol 20% and sodium methoxide 0.08 molar. This solution was rapidly decomposed by air or moisture, but stable for hours under nitrogen.

## Maxima

$\lambda$	I $\epsilon \times 10^{-4}$	$\lambda$	II $\epsilon \times 10^{-4}$	$\lambda$	III $\epsilon \times 10^{-4}$
590	0.860	555	1.86	418	24.8

## Minima

$\lambda$	I $\epsilon \times 10^{-4}$	$\lambda$	II $\epsilon \times 10^{-4}$
578	468	475	0.102

## Beer's law

Concentrations	$3.21 \times 10^{-6} M$	$2.14 \times 10^{-6} M$
$\epsilon \times 10^{-4}$ for peak I	1.86 (3%)	1.84 (7%)
II	0.860 (3%)	0.830 (12%)

TABLE I (Concluded)  
ETIOPORPHYRIN COPPER COMPLEX IN DIOXANE

Maxima			Minima		
$\lambda$	I $\epsilon \times 10^{-4}$	$\lambda$	II $\epsilon \times 10^{-4}$	$\lambda$	III $\epsilon \times 10^{-4}$
563	2.42	527	1.40	398	22.5
Beer's law					
Concentrations			$4.81 \times 10^{-6} M$	$2.89 \times 10^{-6} M$	
$\epsilon \times 10^{-4}$ for peak I			1.40 (2.5%)	1.42 (9%)	
II			2.40 (3%)	2.46 (7%)	

Hilger E-3 Medium Quartz Spectrophotometer with a slit setting of 0.15 mm. Cells 1 cm. thick equipped with quartz windows were used in all cases. The ultraviolet radiation was obtained from a quartz hydrogen discharge tube operating at ten kilovolts. The Eastman Spectroscopic Plates, Type I-O, were developed in Eastman D-76 for twenty minutes at 18°.

The wave length scale was calibrated against the lines of mercury which appeared in the continuous hydrogen spectrum due to contamination from the vapor pump. The deviations between the observed and accepted values for these lines were plotted and a curve drawn, thus giving the deviations at any wave length.

The extinction coefficients were determined by varying the sector setting from  $\log T = 0$  to 1.5 in fifteen steps. The average error in the molar extinction coefficient for the ultraviolet was therefore about  $\pm 4\%$ .

**The Compounds.** Etioporphyrin II.—Synthetic etioporphyrin II was purified by chromatographic adsorption on activated alumina. The product was finally crystallized three times from purified chloroform-methanol. Large crystals were obtained by allowing the methanol to diffuse into a concentrated solution of the porphyrin. The crystals were washed with methanol, powdered, and dried at 100° under high vacuum.

**N-Methyletioporphyrin II.**—The material was purified in a manner similar to that used for etioporphyrin II.

**Etioporphyrin II Copper Complex.**—One hundred milligrams of purified etioporphyrin II was dissolved in 3 ml. of glacial acetic acid in a 15-ml. centrifuge tube equipped with stirrer and heated by means of a water-bath. One half milliliter of a hot saturated solution of copper acetate in 50% acetic acid was added drop by drop, whereupon the solution gradually turned an intense red, and the complex began to separate. Heating and stirring were continued for ten minutes, the mixture allowed to cool slowly to room temperature and the solid centrifuged down. It was washed with hot distilled water until the supernatant liquid no longer gave a positive copper test with ammonium sulfide; yield, 112 mg. or 98%.

The crude product was dissolved in 5 ml. of hot purified

chloroform, filtered by mild suction, and 5 ml. of hot glacial acetic acid added slowly to the center of the liquid. Much of the chloroform boiled off leaving a clear supersaturated solution. The glass stopper was inserted and the flask plunged into a beaker of hot water and gradually cooled to ice temperature. The copper complex separated as a mat of fluffy brilliant red needles, which were washed with 50% acetic acid, water and vacuum dried.

Recrystallization was repeated twice more. The final product was finely powdered and dried at 100° under high vacuum.

**The Solutions.**—Freshly prepared solutions were used in all cases, air being excluded as much as possible.

The dioxane was refluxed under nitrogen for two hours over carefully washed sodium amalgam. Distillation was carried out in a one-piece all-glass apparatus. The nitrogen was purified by passage through a tube filled with activated copper at 450° followed by a drying system of calcium chloride and magnesium perchlorate. The active copper was prepared by packing the tube with fine copper oxide wire and reducing with hydrogen. Asbestos plugs were placed every three centimeters to prevent channeling.

### Summary

1. The two hydrogens of the inner ring of the porphyrin molecule are constrained between adjacent nitrogens in a manner highly favorable to an extreme form of hydrogen bridging. Sharing of hydrogens would increase the symmetry of the aromatic ring from two to four and thus alter the absorption spectrum.

2. The spectra of the porphyrin acid and basic salts and the copper complex were determined. These possess fourfold symmetry.

3. The spectrum of the N-CH<sub>3</sub> porphyrin which has only twofold symmetry was determined.

4. Comparison of the absorption spectrum of porphyrin with the above examples indicates that under the favorable conditions existing in the porphyrin ring, bridging does not occur to an extent which would alter appreciably the electronic energy of the molecule.

BALTIMORE, MD.

RECEIVED MARCH 22, 1946